



Amber TruFLEX® With Integrated Daytime Running Lights Installation Instructions

We thank you for purchasing the Custom Dynamics® Amber TruFLEX® With Integrated Daytime Running Lights. Our products utilize the latest technology and high quality components to ensure you the most reliable service. We offer one of the best warranty programs in the industry and we back our products with excellent customer support, if you have questions before or during installation of this product please call Custom Dynamics® at 1(800) 382-1388.

Part Number: TF30AWS-C

Package Contents:

- Amber/White TruFLEX Strip (1)
- Posi-Lock™ Connectors (4)
- 3M Promoter Ampule (1)
- AWCONVERTER (1)

Fits: 12VDC systems with a negative ground.



Please read all Information below before Installation

Warning: Disconnect negative battery cable from battery; refer to owner's manual. Failure to do so may result in electrical shock, injury, or fire. Secure negative battery cable away from positive side of battery and all other positive voltage sources on vehicle.

Safety First: Always wear appropriate safety gear including safety glasses when performing any electrical work. It is highly recommended that safety glasses be worn throughout this installation process. Be sure vehicle is on level surface, secure and cool.

Important: This product is designed and intended for use as auxiliary lighting only. It is NOT intended to replace any original equipment lighting installed on the vehicle and should not be used for that purpose. This product must be wired so that it does not interfere with any original equipment lighting.

Important: It is recommended that the installation of this product should be performed in a controlled environment of 65 F or above. Allow 24 hours for the tape to properly adhere before riding or washing the vehicle.

Note: Some wiring knowledge may be needed for this installation. Consult your vehicle detailed service manual for wiring information and color codes. Use a meter or test light to verify wiring before tapping any vehicle wiring. If the steps contained within are beyond your skillset, do not attempt installation, contact a qualified mechanic or dealership to assist you.

Note: TruFLEX® products are very flexible but will NOT accommodate hard 90 degree angles. Doing so can cause stress to the board and the LEDs. The product also does not flex from side-to-side, it must be installed in a straight line. Damage or failure from these types of incorrect installation is not covered under warranty.

Note: 3M Adhesion promoter is classified as a sensitive chemical and cannot ship any carrier by Air or international. Custom Dynamics may not be able to ship promoter with orders in these cases. Contact us for details.

Posi-Lock™ Connectors

EASY AS ① ② ③

① Strip wire 1/2"



② Insert



③ Hand tighten



LED Installation

1. Choose the desired location to mount the LED strip.
2. Clean the surface thoroughly before mounting with appropriate cleaning method and rubbing alcohol.

Note: It is recommended to apply 3M adhesion promoter to the mounting surface to increase tape adhesion. If 3M Promotor ampule was included in this kit (see attention section for Promoter notice), open the vial and apply generously to the mounting surface. Allow 3-4 minutes to dry.

3. Inspect the vehicle and plan the route the wiring will make to the connection point. Keep in mind each unit has 36" of wiring. Consult vehicle detailed service manual for vehicle wiring information and wire color codes. Use a meter or test light to verify vehicle wire functions before connecting.
4. Drill holes if necessary in the mounting surface to allow for the wiring to pass. Feed the wiring through the holes.

Questions? Call us at: 1 (800) 382-1388 M-TH 8:30AM-5:30PM / FR 9:30AM-5:30PM EST

Installation Instructions - Page 2

- Remove the Red backing from the Tape and carefully mount in the desired location, paying attention to the desired level and center. Take care in this step as once the tape adheres to the surface, it will be very hard to remove and re-apply and is not recommended.
- Dress the wiring with shrink tubing (not included) as needed to protect wiring from sharp metal or openings, then run the wiring along the chosen route from step 4. Make sure wiring cannot be accidentally cut, pinched, or frayed by moving or sharp parts. Keep wiring from coming in direct contact with high heat components.
- Once you have reached the chosen connection point to the vehicle electrical system, trim any excess wiring from LED wires the and prepare the wiring ends by stripping back the insulation.

Wiring the Connections

- Using the provided Posi-Lock Connectors, Attach each connector to the 4 wire side (output) of the AW Converter. See Posi-Lock instructions on first page.
- Test the LED strip on a power source away from the vehicle, such as a 9 volt battery or DC power supply, verify which black ground wire is for which color LEDs, make note of the grounds as it matters which ground is connected to the AW Converter for proper operation.
- Attach wiring from the LED Strip to the open ends of the posi-Lock connectors on the AW Converter. The wire colors should match each other.
- Attach the 3 wires from the input side of the AW Converter to the appropriate wiring on the vehicle, using the appropriate method. The Black goes to the vehicle ground, the White to running or accessory power, and Yellow to the Left or right turn signal wire.
- Make sure the battery is connected, then test function of the LED strip. You should have a running light when the ignition is on, then turn off and engage the amber LEDs when the turn signal is engaged on the vehicle.

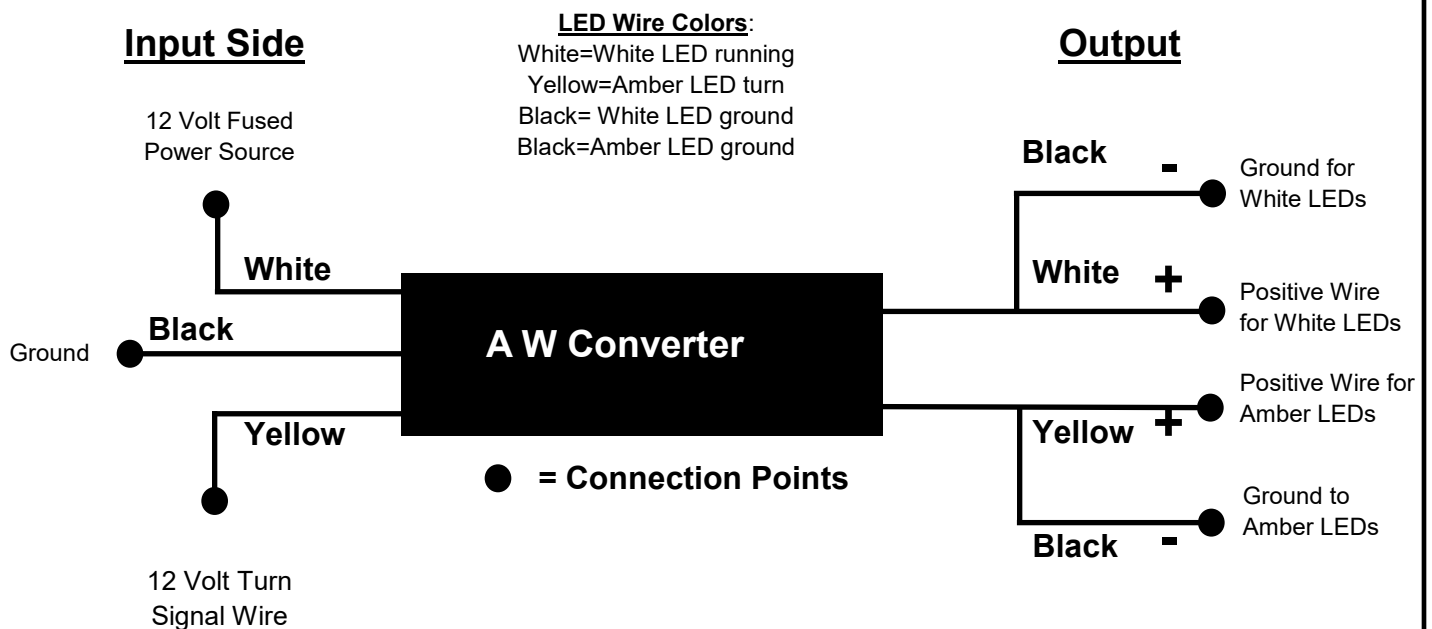

Questions? Call us at: 1 (800) 382-1388 M-TH 8:30AM-5:30PM / FR 9:30AM-5:30PM EST