

Over Armour Offroad

2515 KY HWY 11 BYPASS Rd. Flemingsburg, KY 41041

606-845-7439

Instructions for Installation and Care of

2010 Ranger Crew

Folding Polycarbonate Windshield

1. Check over the parts included in the carton with the parts list shown below:

1-3/4" loom clamps	8 each
1" stainless steel bolts	16 each
1-1/4" stainless bolts	2 each
Thumbnuts	8 each
Stainless steel washers	26 each
Stainless steel locknuts	8 each
Stainless steel nuts	2 each
Rubber gasket	1 each
Polycarbonate windshield	3 pieces (windshield + braces)
2. Pull the windshield and all of the hardware out of the box. Begin by removing all of the protective film from: **a)** the bottom edge contour where the gasket will go and **b)** the areas around the slots at the edges of the windshield. Keep the remainder of the protective film in place during installation to prevent scratching.
3. Now take the rubber gasket provided and install it along the bottom of the windshield. Take care to seat the gasket **fully** to the bottom edge contour. Install the top and bottom braces using (1) 1" stainless bolt, (1) stainless locknut, and (2) stainless washers per hole. On most models, the bottom brace is widest (installed **inside** the windshield), with the narrower brace used at the top (installed **outside** the windshield). Other models use the same brace top and bottom. The bolts should be installed through the front of the windshield with the bolt head facing forward, the locknuts on the back of the windshield facing rearward, with one washer under the bolt head and one washer behind the locknut at the rear. Install both braces using this sequence; even though the bottom brace is installed inside the windshield the bolt heads should still face forward, and hardware orientation remains the same as stated above (see fig.1). **Note: if you are installing with a Over Armour Offroad cab enclosure, wait until you have fully installed the enclosure and fitted the windshield to bolt the upper brace to the windshield. The upper brace is bolted to the windshield on the outside through the front visor of the cab enclosure as shown in fig. 1 and should be the final step in the installation.** Now you are ready to place the windshield on your vehicle. With help, place the windshield onto the hood. The rubber gasket should temporarily hold it up, but be careful. The bent angle at the top of the windshield should go underneath the top bar of the roll cage. Near the top slot in the top windshield, take a 1-3/4" clamp and wrap it around the roll cage tube and then run a bolt with a washer through both ears of the clamp from the inside out (see fig. 2). Then run a thumbnut onto the bolt from the front. Repeat at all other slot locations.

4. Before tightening down make sure that the windshield is centered. After the windshield is centered satisfactorily, tighten everything down using moderate torque; **DO NOT OVERTIGHTEN**. Overtightening will mangle the clamps and distort the Lexan. Peel the remaining protective film from both sides of the windshield.
5. Refer to figs. 3 and 4 for information on how to install the lower windshield holding clamps, and for clarity on how to raise and lower the folding part of the windshield. The lowermost slot on the *upper* windshield will be unique; install hardware at this location according to fig.3.
6. Enjoy, and remember- when cleaning the windshield do so gently at first with warm water and mild detergent to dislodge any grit that may scratch the Lexan. After rinsing and drying with a soft cloth, you may then polish the windshield with an appropriate commercially available plastic polish, also available from Over Armour Offroad. This will ensure many seasons of clarity and keep scratching and swirling to a minimum. Never use cleaners such as Windex that contain ammonia as doing so may adversely affect the windshield.
7. If needed, additional spare parts and hardware are available. Contact Over Armour Offroad for information.
8. Transporting or trailering your UTV with the windshield installed is not generally recommended. It is best to remove the windshield before transporting your UTV.

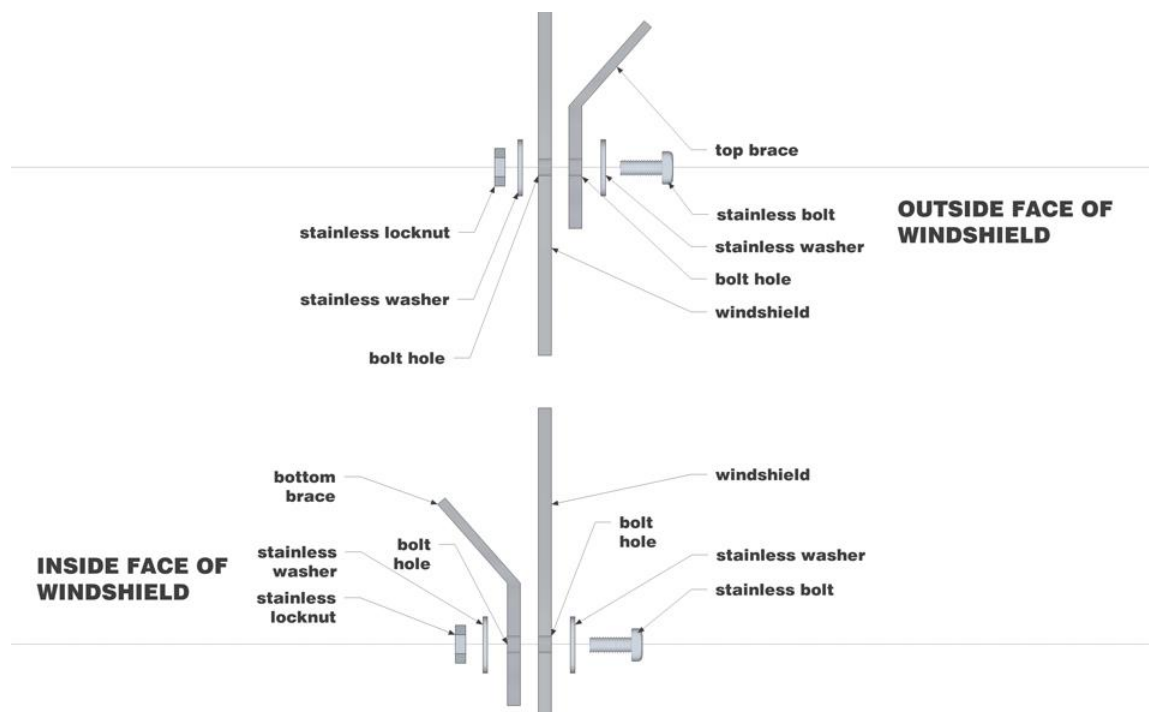

Fig.1

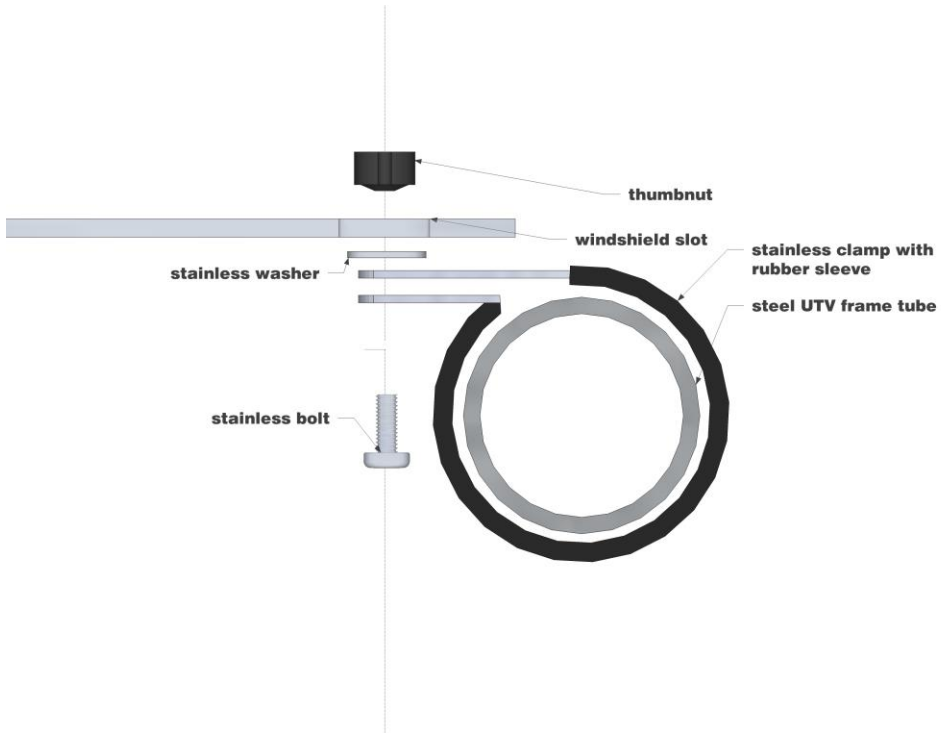

Fig.2

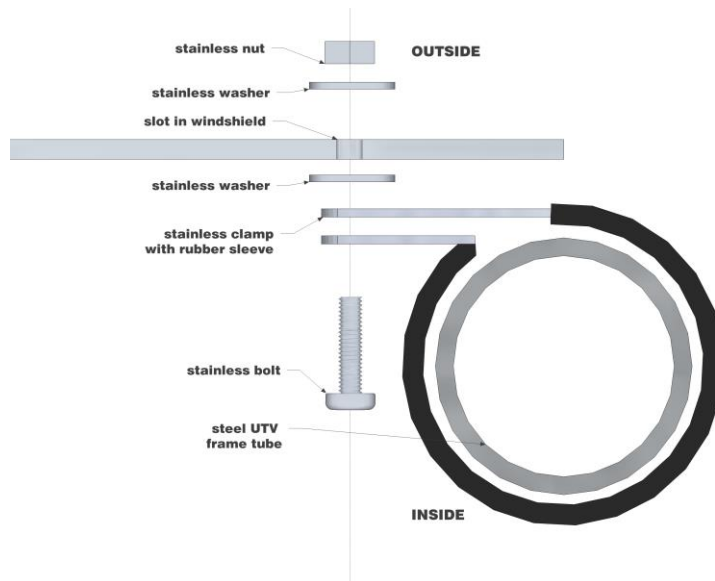

Fig. 3

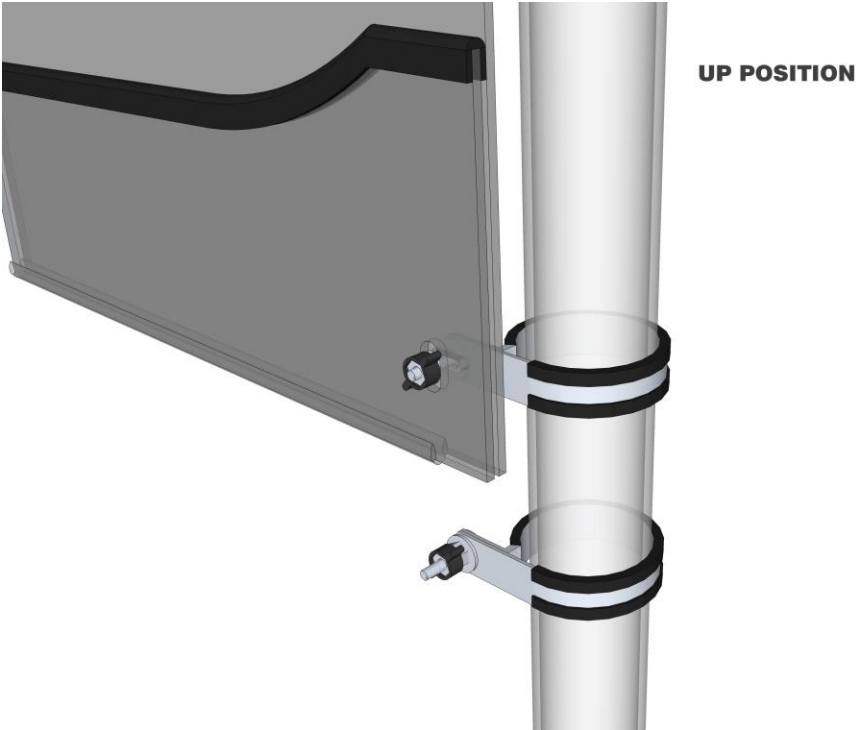
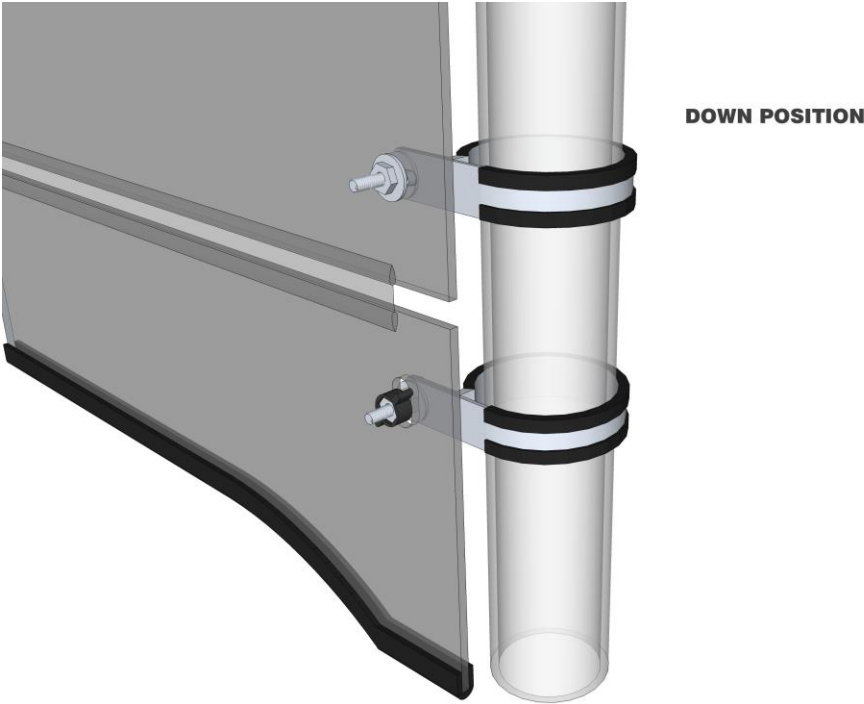

Fig.4

Return Policy

Over Armour Offroad

2515 Bypass Rd, Flemingsburg, KY 41041
Phone: 606-845-7439

If for any reason you choose to return this product it must be returned within **30 days from date item is received**. You **MUST** package the product exactly as it was **originally packaged from the factory to get a full refund for the product!**

The vinyl windows should never be folded when packaging in the box or for storage purposes. Lay all the windows on top of each other with the canvas folded in between and the paper (if available) on both sides of the windows.

All returned products will be inspected upon arrival at the production facility and must be in unused, factory new condition to receive refund - a 20% restocking fee will apply.

If ordered from Over Armour Offroad please call at 606-845-7439 to gain a return authorization number, use our preferred shipping carrier (UPS) to return the item (unless the item is defective, you are responsible for paying the shipping to return the item.) **Any returns submitted to Over Armour Offroad without a return authorization number will be charged a 20% restocking fee.** If ordered from one of Over Armour Offroads many distributors', you must first call them and see what their return policy is. Once your item reaches our production facility, our customer satisfaction team will inspect your item to ensure unused, factory new condition. **NOTE: All windshields must be returned with the original protective film intact and not removed. Do NOT REMOVE if you have any intentions of returning the item. Refund/ replacement of a windshield will only be processed on items with original protective film or if the windshield is defective.**

Items must be properly packaged in the original shipping carton to protect them during transit and ensure your returned item arrives back factory fresh, and in new resalable condition (**any returned items that have been used, altered or damaged in any way will not be subject for a refund.**) All contents including instruction manuals, accessories, hardware, Velcro, etc. must be included in your return shipment. Only items in OEM factory new condition will be approved. Once returned items are received, credit will be issued to the original credit card/ payment method used for the purchase. Outbound shipping and return shipping cost will not be refunded. Please allow 4 to 6 weeks for your refund to be processed.

Warranty
Over Armour Offroad
2515 Bypass Rd, Flemingsburg, KY 41041
Phone: 606-845-7439

To The Owner of this Product:

Thank you for purchasing one of Over Armour Offroad Cab Enclosures &/or Windshields! Below are the terms under which your product is covered under our manufacturer's warranty.

30 Day Warranty which includes and is not limited to replacing the enclosure and/or windshield due to defect of the product. Please refer to the return policy in this case for more information.

1 Year Warranty includes any defect in material or workmanship within this time frame we will gladly correct the problem or replace the enclosure &/or windshield. Upon submitting for the correction or replacement we will need to receive pictures of the defect in material or workmanship along with the receipt from the date of purchase.

Thank you,

Darren Royse
Owner/Operator

www.overarmouroffroad.com