

Ranger Bed Rail Installation Kit

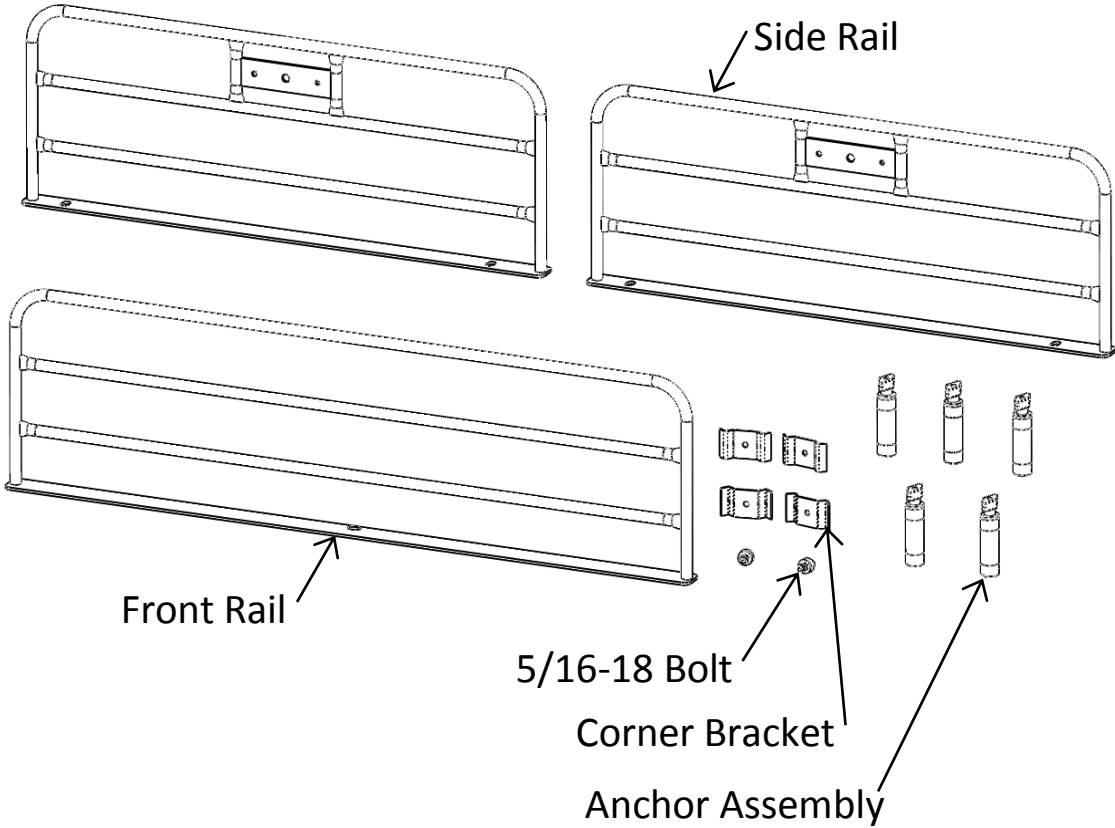

The Ranger BR 500 Bed Rail Installation Kit fits Ranger Mid-Size Models 400, 500, 570, EV & 800. The BR-800 Kit fits Ranger Full-Size Models XP700, 800 & 900. The Kit comes with 2x Side Rails, a Front Rail, 4x Corner Brackets, 2x 5/16-18 Bolt Sets (Bolt, Lock Washer, 2x Flat Washer, and T- Knob) and 5x Anchor Assemblies.



Installation:

Step 1:

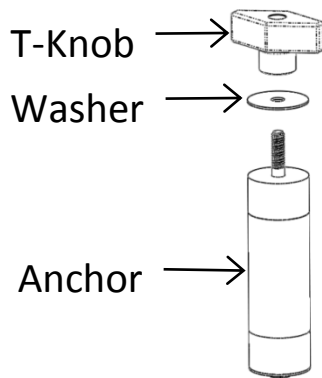

Remove the T-Knob and Washer from each of the Anchor Assemblies.

Step 2:

Insert an Anchor Assembly into each of the slots in both the Side Rails and the Front Rail.

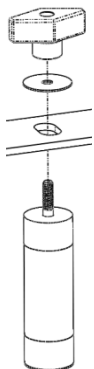
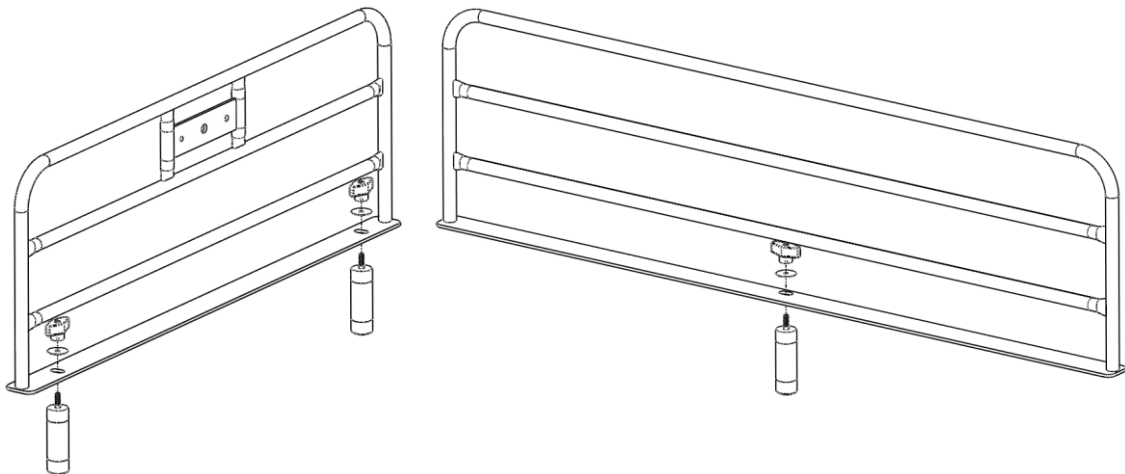

The threads of the Anchor Assembly will fit up into the slots. Replace the Washer and T-Knob. Screw the T-Knob and Washer down until it is finger tight but can still slide freely in the slot.

Do NOT tighten beyond finger tight at this point.

Step 3:

Lift one of the Side Rails into place, locating both of the Anchor Assemblies into a Mounting Hole located on the Ranger Bed side.

If an Anchor will not enter a mounting hole, make sure that none of the T-Knobs are threaded too tight.



Step 4:

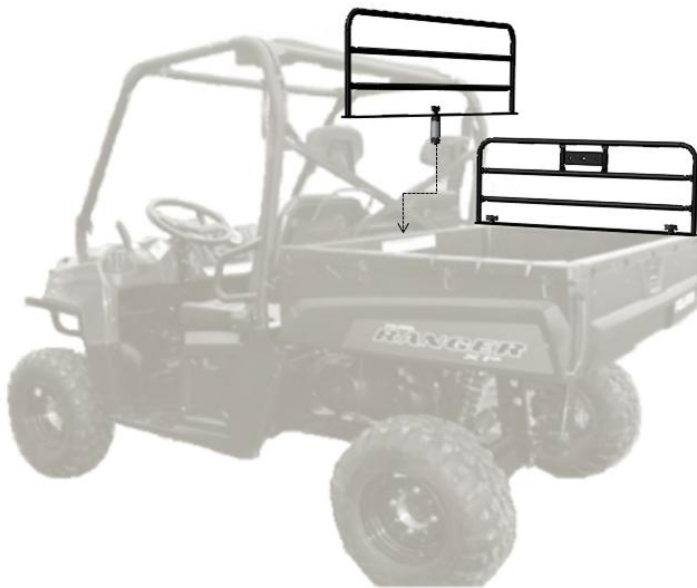

Place the Front Rail on the front of the Bed. Note that the slot is off-centered and that the slot should be towards the front of the Ranger.

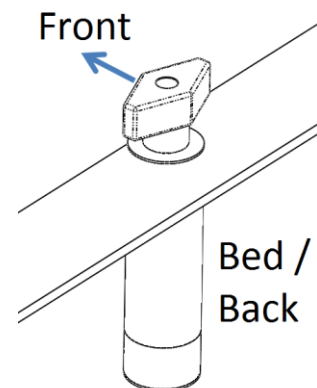

Step 5:

Place the second Side Rail onto the remaining bed side.

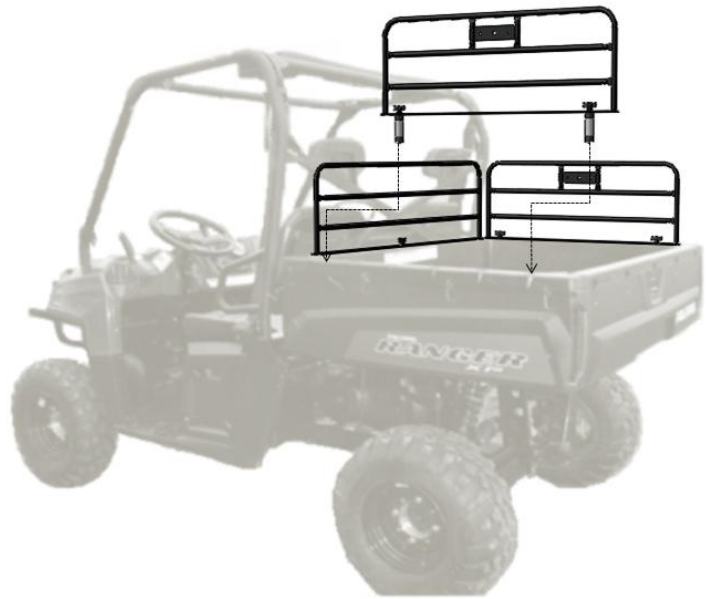

Step 6:

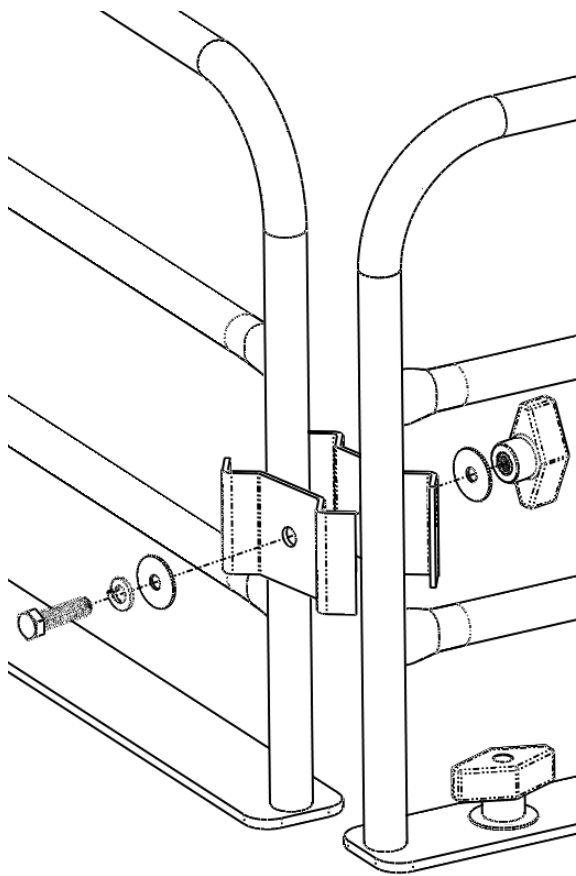

At both corners, place 2 of the Corner Brackets across the Front Rail and the Side Rail. Bolt together using the 5/16-18 Bolt with a Lock Washer and Washer on one side and a Washer and T- Knob on the other.

To finish installation, tighten the T-Knobs of each Anchor Assembly.