



# Polaris Ranger XP900 Pro Series Roof Installation Instructions

Stock No.: 4452

Please read and understand these instructions completely before installation to avoid injury to yourself or damage to the vehicle or accessory.

**Dealer:** These instructions contain important information for future reference and must be given to the customer at time of purchase or upon completion of installation.

## Parts List:

ITEM	PART NAME	PART NO.	DESCRIPTION (60-4452)	QTY.
1	Roof	10-4452	Polaris Ranger XP900 Pro Series Roof	1
2	Clamp	52-0029	2.375" Diameter "P" Type Clamp	2
3	Screw	75-7519	M6 x 1.0 x 25mm Torx Head Screw	8
4	Washer	76-6329	0.281" I.D. x 0.875" O.D. Fender Washer	8
5	Washer	76-0035	0.25" I.D. x 0.625" O.D. Bonded Sealing Washer	8
6	Nut	77-7547	M6 x 1.0 Hex Flange Nylock Nut	8

1) Viewing your vehicle from above, and illustrated in **Image A1**, please note the suggested roof mounting points. They are represented with arrows on the cab frame.

The arrows noted as "1" indicate mounting straight through the vehicle's cab frame. Arrows noted as "2" indicate using the "P" Type Clamp around the cab frame.

2) Wrap the two "P" Type Clamps around the sides of the cab frame as indicated in **Image A2**. Please note the tabs of the clamps face **OUTWARD**.

3) Place the **Pro Series Roof** on the vehicle with the logo facing toward the front as indicated in **Image A3**.

4) Once the roof and clamps are into position, clearly mark the eight (8) recommended mounting points. There will be six (6) through the vehicles cab frame and two (2) through the clamps.

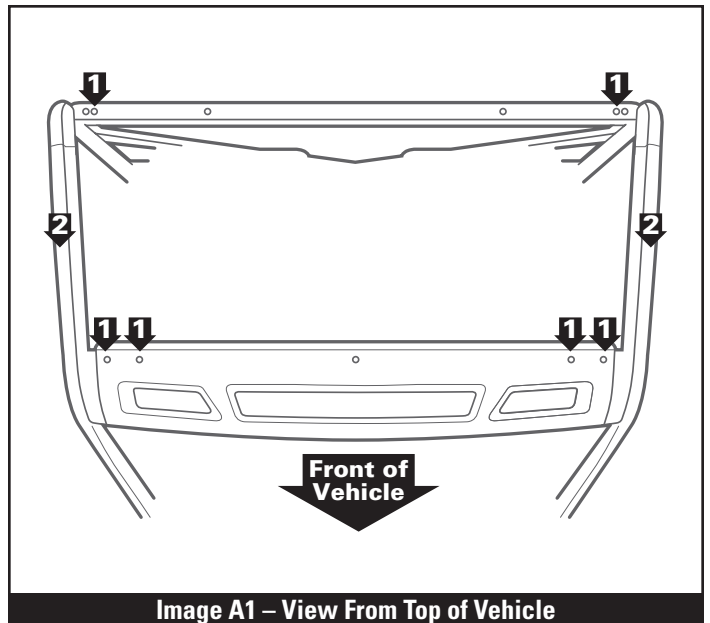

Image A1 – View From Top of Vehicle

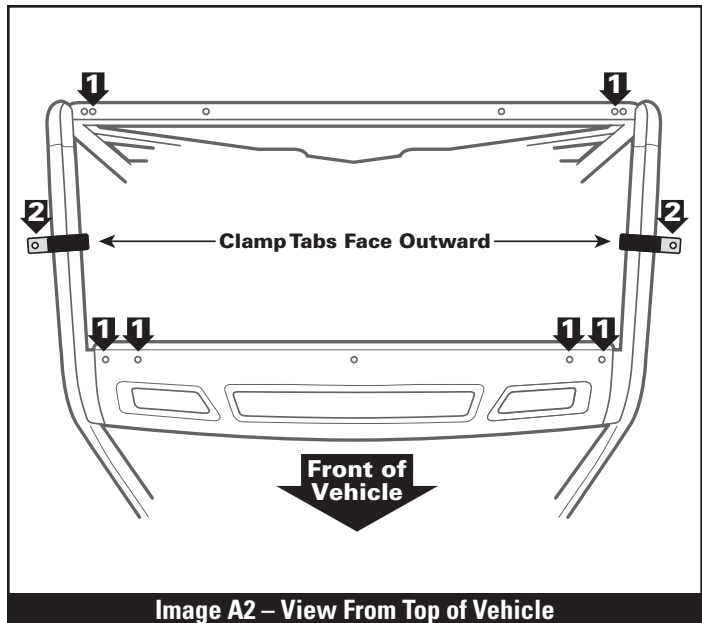

Image A2 – View From Top of Vehicle

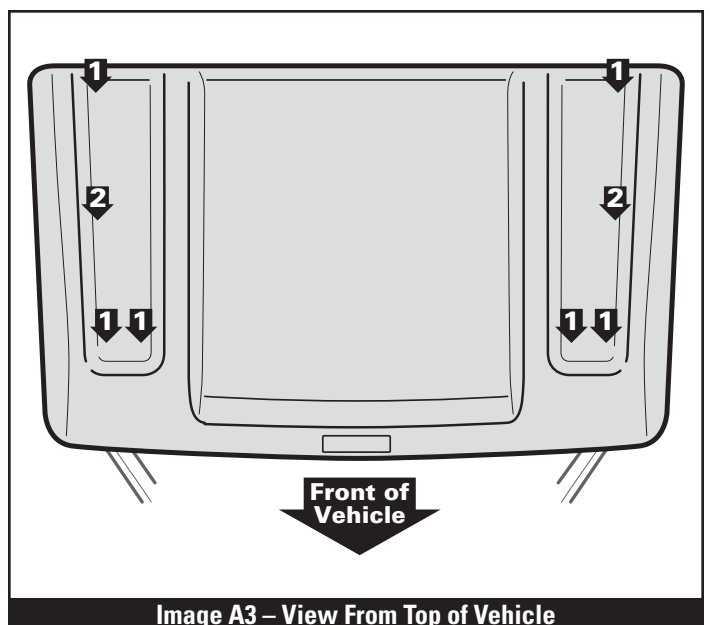
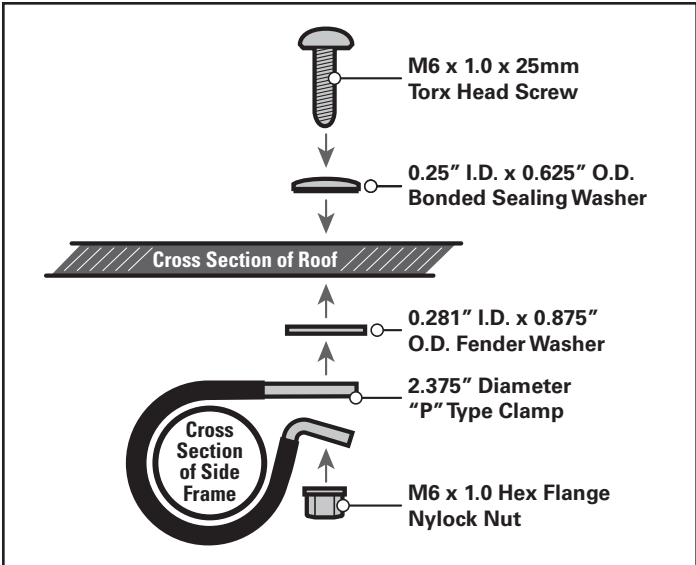

Image A3 – View From Top of Vehicle

- 5) Remove the roof and with an M6 bit, **CAREFULLY** drill the roof in the eight (8) marked locations.
- 6) Place the roof back on the vehicle and align the suggested mounting points with the holes you just drilled.
- 7) As illustrated in **Image B1**, attach the roof to the clamps using the **M6 Screws, Fender Washers, Sealing Washers** and **M6 Nut**. **DO NOT completely tighten at this point.**
- 8) As illustrated in **Image B2**, attach the roof to the cab frame using the M6 Screws, Fender Washers, Sealing Washers and M6 Nut. **DO NOT completely tighten at this point.**
- 9) Check the alignment and positioning of the roof. Once you are satisfied with its location, continue to **COMPLETELY TIGHTEN** all of the hardware.
- 10) **Maintenance and Care:** Tighten all hardware after first use and periodically thereafter.

**⚠ WARNING** Failure to follow these installation instructions completely may void any warantable components and result in property damage or personal injury **NEVER** operate or transport UTV with unsecured cargo. For additional assistance, please contact our customer service department at:

Kolpin Outdoors, Inc.  
 205 N. Depot Street | Fox Lake, WI 53933 | 1.877.956.5746  
 customerservice@kolpin.com



**Image B1 – Hardware Configuration for Clamp Mounts**

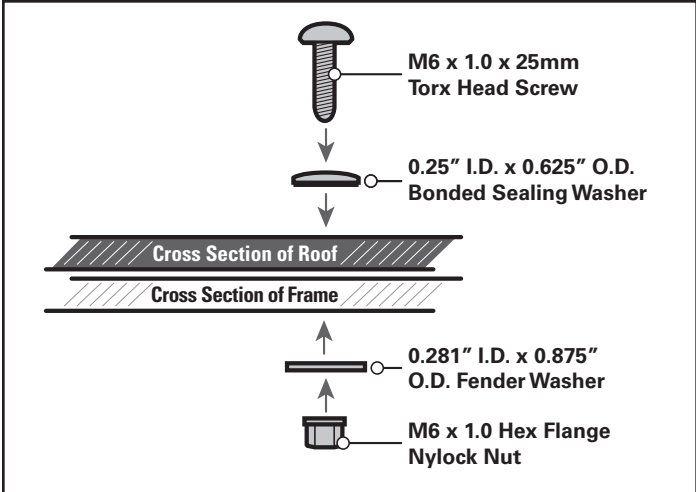

**Image B2 – Hardware Configuration for Non-Clamp Mounts**

